

Crane Copper Tube



PropressTM
GAS

PropressTM
WATER

Crane Copper Tube

ABN 51 008 408 151
A Division of
Crane Enfield Metals
Pty Limited

PO Box 319,
Penrith, NSW 2751
Phone: 02 4720 5350
Fax: 02 4720 5390
sales@cranecopper.com.au
www.cranecopper.com.au

For Viega enquires please call:
1800 043 117

Dimensions in mm

Coupling with Stops (No.1)

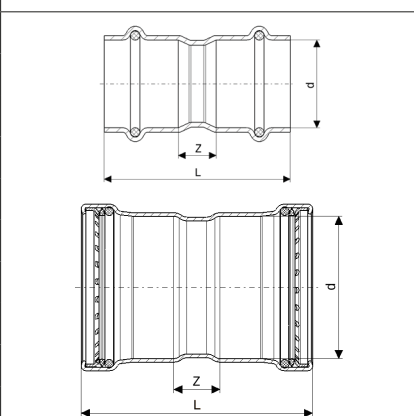

| d | Z | L |
|-------|------|-------|
| DN15 | 7.0 | 43.0 |
| DN20 | 9.0 | 53.0 |
| DN25 | 10.4 | 56.0 |
| DN32 | 10.6 | 60.0 |
| DN40 | 10.4 | 72.0 |
| DN50 | 10.4 | 88.0 |
| DN65 | 24.0 | 110.0 |
| DN80 | 25.0 | 125.0 |
| DN100 | 27.0 | 147.0 |

Reducer (Reduces a Viega Fitting)

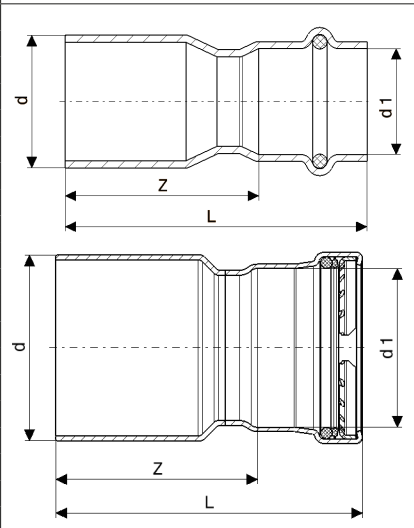

| d x d1 | Z | L |
|----------|-------|-------|
| DN20x15 | 37.0 | 55.0 |
| DN25x15 | 45.0 | 63.0 |
| DN25x20 | 37.0 | 59.0 |
| DN32x20 | 47.0 | 69.0 |
| DN32x25 | 39.0 | 62.0 |
| DN40x20 | 56.0 | 78.0 |
| DN40x25 | 49.0 | 72.0 |
| DN40x32 | 41.5 | 66.5 |
| DN50x25 | 72.0 | 95.0 |
| DN50x32 | 64.0 | 89.0 |
| DN50x40 | 56.0 | 87.0 |
| DN65x40 | 74.5 | 105.5 |
| DN65x50 | 56.5 | 95.5 |
| DN80x40 | 100.0 | 131.0 |
| DN80x50 | 94.0 | 133.0 |
| DN80x65 | 92.0 | 135.0 |
| DN100x50 | 117.0 | 156.0 |
| DN100x65 | 115.0 | 158.0 |
| DN100x80 | 107.0 | 157.0 |

Reducing Coupling (No.1R)

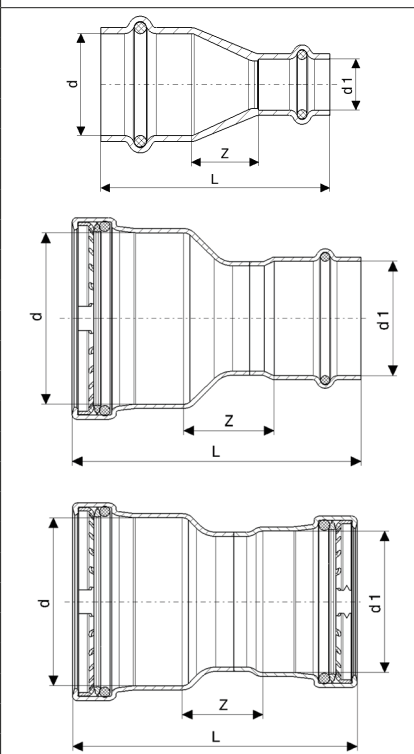

| d x d1 | Z | L |
|----------|------|-------|
| DN18x15 | 8.5 | 45.5 |
| DN20x15 | 9.5 | 49.5 |
| DN20x18 | 7.5 | 48.5 |
| DN25x15 | 17.0 | 58.0 |
| DN25x20 | 11.0 | 56.0 |
| DN32x15 | 24.0 | 67.0 |
| DN32x20 | 18.0 | 65.0 |
| DN32x25 | 14.0 | 62.0 |
| DN40x20 | 24.5 | 77.5 |
| DN40x25 | 18.0 | 72.0 |
| DN40x32 | 11.0 | 67.0 |
| DN50x20 | 38.5 | 99.5 |
| DN50x25 | 32.0 | 94.0 |
| DN50x32 | 25.0 | 89.0 |
| DN50x40 | 18.5 | 88.5 |
| DN65x32 | 42.5 | 110.5 |
| DN65x40 | 42.0 | 116.0 |
| DN65x50 | 34.5 | 116.5 |
| DN80x40 | 48.0 | 129.0 |
| DN80x50 | 40.5 | 129.5 |
| DN80x65 | 36.7 | 129.7 |
| DN100x50 | 54.5 | 153.5 |
| DN100x65 | 50.5 | 153.5 |
| DN100x80 | 43.5 | 153.5 |



Crane Copper Tube



Propress[™]
GAS

Propress[™]
WATER

Crane Copper Tube

ABN 51 008 408 151

A Division of
Crane Enfield Metals
Pty Limited

PO Box 319,
Penrith, NSW 2751
Phone: 02 4720 5350
Fax: 02 4720 5390
sales@cranecopper.com.au
www.cranecopper.com.au

For Viega enquires please call:
1800 043 117

Dimensions in mm

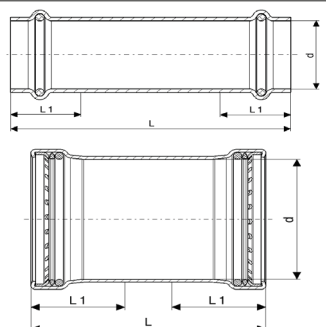
| Repair Coupling (No Stops) | | | |
|---|--------|-------|------|
|  | d x d1 | L | L1 |
| | DN15 | 43.0 | 18.0 |
| | DN20 | 53.0 | 22.0 |
| | DN25 | 56.0 | 23.0 |
| | DN32 | 60.0 | 25.0 |
| | DN40 | 72.0 | 31.0 |
| | DN50 | 88.0 | 39.0 |
| | DN65 | 110.0 | 43.0 |
| | DN80 | 125.0 | 50.0 |
| | DN100 | 147.0 | 60.0 |

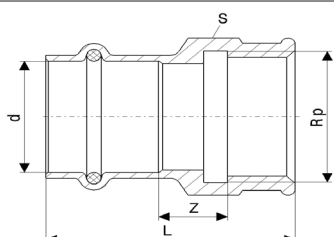
| Female line Adaptor (No.2) | | | | |
|---|-------------|------|------|------|
|  | d x Rp | Z | L | S |
| | DN15x1/2" | 8.0 | 40.5 | 26.0 |
| | DN20x3/4" | 9.6 | 44.0 | 30.5 |
| | DN25x1" | 11.5 | 48.5 | 37.5 |
| | DN32x1 1/4" | 10.6 | 50.0 | 47.0 |
| | DN40x1 1/2" | 8.1 | 62.5 | 53.0 |
| | DN50x2" | 15.3 | 75.0 | 70.0 |

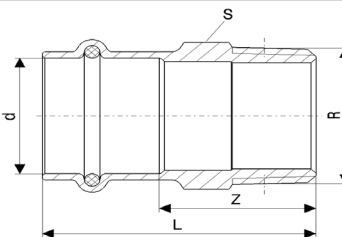
| Male line Adaptor (No.3) | | | | |
|---|-------------|------|------|------|
|  | d x R | Z | L | S |
| | DN15x1/2" | 24.0 | 41.5 | 22.0 |
| | DN20x3/4" | 26.0 | 48.0 | 27.0 |
| | DN25x1" | 30.8 | 53.8 | 34.0 |
| | DN32x1 1/4" | 31.0 | 56.0 | 43.0 |
| | DN40x1 1/2" | 35.0 | 66.0 | 50.0 |
| | DN50x2" | 40.0 | 79.0 | 68.0 |

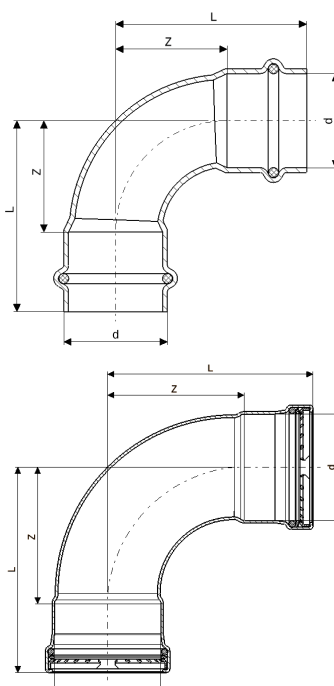
| Elbow 90° (Female-Female No.12) | | | |
|---|-------|-------|-------|
|  | d | Z | L |
| | DN15 | 14.0 | 32.0 |
| | DN20 | 21.5 | 43.5 |
| | DN25 | 30.5 | 53.5 |
| | DN32 | 35.0 | 60.0 |
| | DN40 | 45.5 | 76.5 |
| | DN50 | 61.0 | 100.0 |
| | DN65 | 83.5 | 126.5 |
| | DN80 | 99.0 | 149.0 |
| | DN100 | 122.5 | 182.5 |



Crane Copper Tube



PropressTM
GAS

PropressTM
WATER

Crane Copper Tube
ABN 51 008 408 151
A Division of
Crane Enfield Metals
Pty Limited

PO Box 319,
Penrith, NSW 2751
Phone: 02 4720 5350
Fax: 02 4720 5390
sales@cranecopper.com.au
www.cranecopper.com.au

For Viega enquires please call:
1800 043 117

Dimensions in mm

Elbow 90° (Male - Female)

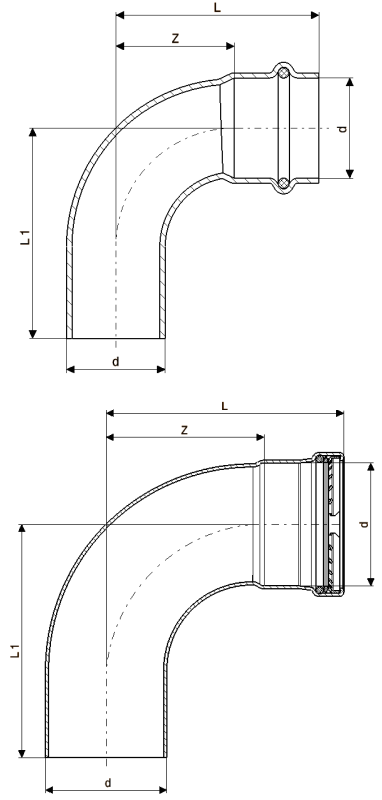

| d | Z | L | L1 |
|-------|-------|-------|-------|
| DN15 | 14.0 | 32.0 | 34.0 |
| DN20 | 21.5 | 43.5 | 46.5 |
| DN25 | 30.5 | 53.5 | 55.5 |
| DN32 | 35.0 | 60.0 | 62.0 |
| DN40 | 45.5 | 76.5 | 78.5 |
| DN50 | 61.0 | 100.0 | 102.0 |
| DN65 | 83.5 | 126.5 | 126.0 |
| DN80 | 99.0 | 149.0 | 146.5 |
| DN100 | 122.5 | 182.5 | 177.5 |

Tee Adaptor (with Female Thread)

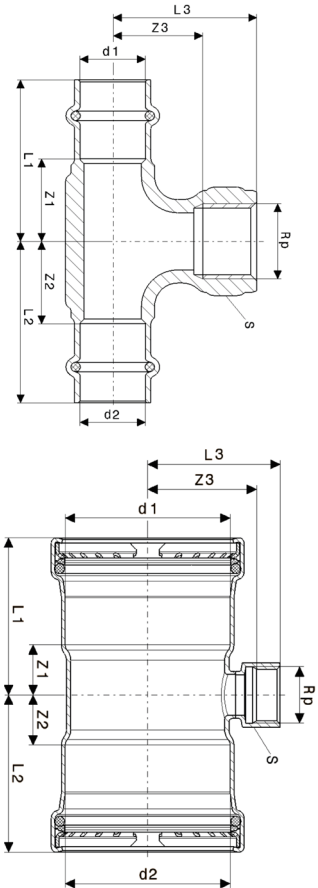

| dxdRp | Z1 | Z2 | Z3 | L1 | L2 | L3 | S |
|----------------|------|------|------|-------|-------|------|------|
| DN25x25x1/2" | 22.0 | 22.0 | 27.0 | 45.0 | 45.0 | 42.0 | 26 |
| DN25x25x3/4" | 24.5 | 24.5 | 30.7 | 47.5 | 47.5 | 47.0 | 32.4 |
| DN32x32x1/2" | 22.5 | 22.5 | 30.0 | 47.5 | 47.5 | 45.0 | 26 |
| DN32x32x3/4" | 22.5 | 22.5 | 33.7 | 47.5 | 47.5 | 50.0 | 32.4 |
| DN40x40x1/2" | 21.5 | 21.5 | 35.0 | 52.5 | 52.5 | 50.0 | 26 |
| DN50x50x3/4" | 28.5 | 28.5 | 43.7 | 67.5 | 67.5 | 60.0 | 32.4 |
| DN65x65x3/4" | 27.0 | 27.0 | 44.8 | 70.0 | 70.0 | 57.8 | 30 |
| DN65x65x2" | 41.0 | 41.0 | 49.3 | 84.0 | 84.0 | 67.3 | 65 |
| DN80x80x3/4" | 26.5 | 26.5 | 52.1 | 76.5 | 76.5 | 64.1 | 30 |
| DN80x80x2" | 39.5 | 39.5 | 55.6 | 89.5 | 89.5 | 73.6 | 65 |
| DN100x100x3/4" | 27.5 | 27.5 | 63.7 | 87.5 | 87.5 | 75.7 | 30 |
| DN100x100x2" | 40.5 | 40.5 | 68.3 | 100.5 | 100.5 | 86.3 | 65 |

Crane Copper Tube



Propress[™]
GAS

Propress[™]
WATER

Crane Copper Tube

ABN 51 008 408 151
A Division of
Crane Enfield Metals
Pty Limited

PO Box 319,
Penrith, NSW 2751
Phone: 02 4720 5350
Fax: 02 4720 5390
sales@cranecopper.com.au
www.cranecopper.com.au

For Viega enquires please call:
1800 043 117

Tee & Reducing Tee

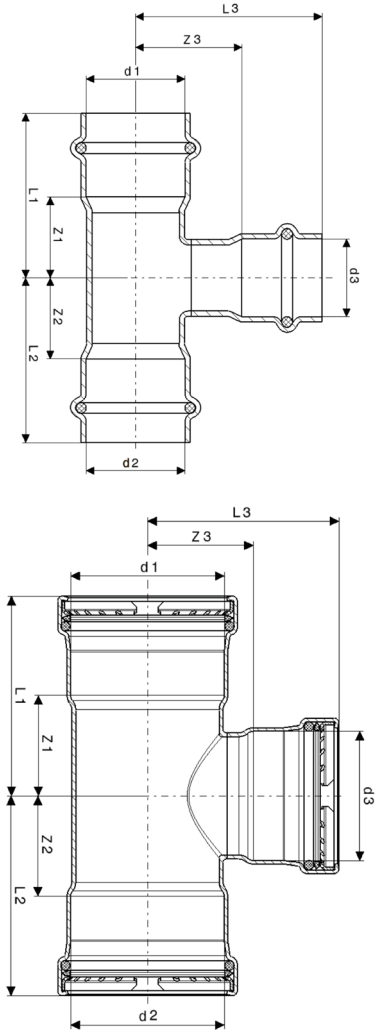

| d1xd2xd3 | Z1 | Z2 | Z3 | L1 | L2 | L3 |
|--------------|------|------|------|-------|-------|-------|
| DN15 | 15.0 | 15.0 | 10.0 | 33.0 | 33.0 | 28.0 |
| DN20 | 20.0 | 20.0 | 14.0 | 42.0 | 42.0 | 36.0 |
| DN20x15x15 | 15.0 | 22.5 | 14.0 | 37.0 | 40.5 | 32.0 |
| DN20x20x15 | 17.0 | 17.0 | 14.0 | 39.0 | 39.0 | 32.0 |
| DN20x15x20 | 20.0 | 25.0 | 20.0 | 42.0 | 43.0 | 42.0 |
| DN25 | 23.0 | 23.0 | 17.5 | 46.0 | 46.0 | 40.5 |
| DN25x25x15 | 15.5 | 15.5 | 17.5 | 38.5 | 38.5 | 35.5 |
| DN25x25x20 | 19.5 | 19.5 | 17.5 | 42.5 | 42.5 | 39.5 |
| DN32 | 25.5 | 25.5 | 21.5 | 49.5 | 49.5 | 46.5 |
| DN32x32x15 | 15.5 | 15.5 | 21.0 | 39.8 | 39.8 | 39.0 |
| DN32x32x20 | 18.5 | 18.5 | 21.0 | 43.5 | 43.5 | 43.0 |
| DN32x32x25 | 21.5 | 21.5 | 21.0 | 46.5 | 46.5 | 44.0 |
| DN40 | 27.0 | 27.0 | 27.0 | 58.0 | 58.0 | 58.0 |
| DN40x40x25 | 20.5 | 20.5 | 27.0 | 51.5 | 51.5 | 50.0 |
| DN40x40x32 | 23.5 | 23.5 | 27.0 | 54.5 | 54.5 | 52.0 |
| DN50 | 33.5 | 33.5 | 33.5 | 72.5 | 72.5 | 72.5 |
| DN50x50x20 | 18.0 | 18.0 | 33.5 | 57.0 | 57.0 | 55.5 |
| DN50x50x25 | 20.5 | 20.5 | 33.5 | 59.5 | 59.5 | 56.5 |
| DN50x50x32 | 23.5 | 23.5 | 33.5 | 62.5 | 62.5 | 58.5 |
| DN50x50x40 | 27.0 | 27.0 | 33.5 | 66.0 | 66.0 | 64.5 |
| DN65 | 46.0 | 46.0 | 48.1 | 89.0 | 89.0 | 91.0 |
| DN65x65x50 | 41.0 | 41.0 | 44.8 | 84.0 | 84.0 | 83.8 |
| DN80 | 50.5 | 50.5 | 52.5 | 100.5 | 100.5 | 102.5 |
| DN80x80x50 | 39.5 | 39.5 | 50.9 | 89.5 | 89.5 | 89.9 |
| DN80x80x65 | 42.8 | 42.8 | 53.1 | 92.8 | 92.8 | 96.1 |
| DN100 | 67.5 | 67.5 | 68.3 | 127.5 | 127.5 | 128.3 |
| DN100x100x50 | 45.0 | 45.0 | 64.3 | 105.0 | 105.0 | 103.3 |
| DN100x100x65 | 45.0 | 45.0 | 67.1 | 105.0 | 105.0 | 110.1 |
| DN100x100x80 | 51.5 | 51.5 | 67.2 | 111.5 | 111.5 | 117.2 |

Cap (DN65, 80,100 with Female Thread)

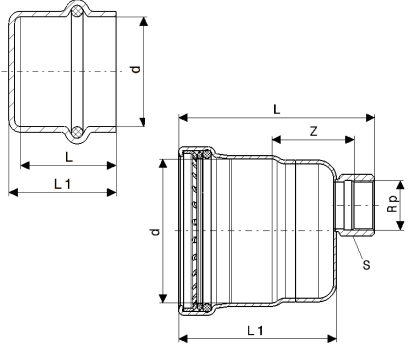

| d (xRp) | Z | L1 | L2 |
|------------|------|------|-------|
| DN15 | - | 21.0 | 24.0 |
| DN20 | - | 25.0 | 28.0 |
| DN25 | - | 26.0 | 29.0 |
| DN32 | - | 31.0 | 32.5 |
| DN40 | - | 33.5 | 37.0 |
| DN50 | - | 41.5 | 45.0 |
| DN65 (¾") | 45.8 | 78.3 | 100.8 |
| DN80 (¾") | 45.0 | 84.5 | 107.0 |
| DN100 (¾") | 46.0 | 95.5 | 118.0 |

Dimensions in mm



Crane Copper Tube



Propress[™]G
GAS

Propress[™]
WATER

Crane Copper Tube

ABN 51 008 408 151

A Division of
Crane Enfield Metals
Pty Limited

PO Box 319,
Penrith, NSW 2751
Phone: 02 4720 5350
Fax: 02 4720 5390
sales@cranecopper.com.au
www.cranecopper.com.au

For Viega enquires please call:
1800 043 117

Dimensions in mm

Elbow 45° (Female - Female)

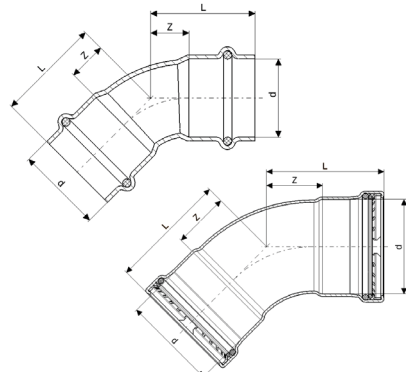

| d | Z | L |
|-------|------|-------|
| DN25 | 12.6 | 35.6 |
| DN32 | 14.5 | 39.5 |
| DN40 | 18.9 | 49.9 |
| DN50 | 25.3 | 64.3 |
| DN65 | 39.2 | 82.2 |
| DN80 | 45.5 | 95.5 |
| DN100 | 57.5 | 117.5 |

Elbow 45° (Male - Female)

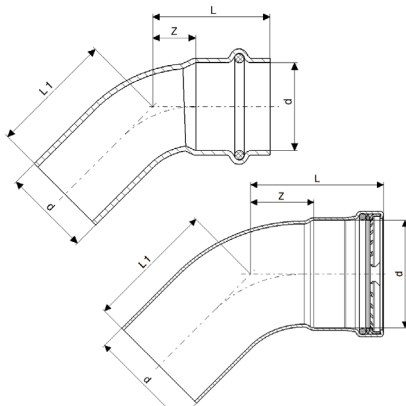

| d | Z | L | L1 |
|-------|------|-------|-------|
| DN25 | 12.6 | 35.6 | 37.6 |
| DN32 | 14.5 | 39.5 | 41.5 |
| DN40 | 18.9 | 49.9 | 51.9 |
| DN50 | 25.3 | 64.3 | 66.3 |
| DN65 | 39.2 | 82.2 | 81.7 |
| DN80 | 45.5 | 95.5 | 93.0 |
| DN100 | 57.5 | 117.5 | 112.5 |

Back-plated Female Elbow (15BP)

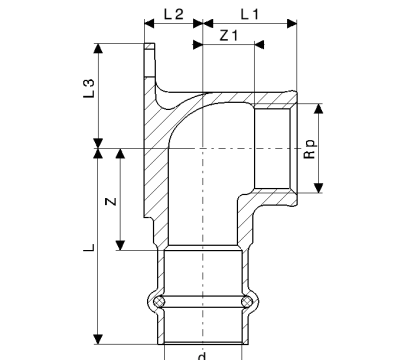

| dxRp | Z | Z1 | L | L1 | L2 | L3 |
|---------|------|------|------|------|------|------|
| DN15x½" | 25.0 | 10.8 | 42.5 | 20.0 | 11.0 | 21.5 |
| DN20x¾" | 25.5 | 14.8 | 47.5 | 25.0 | 15.0 | 21.5 |

Back-plated Male Elbow (19BP)

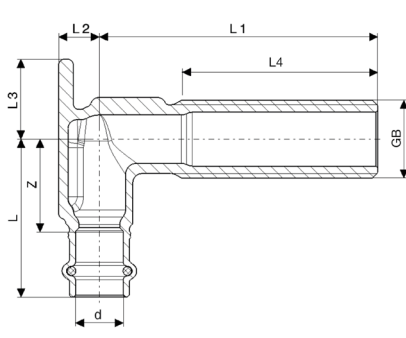

| dxGBxL1 | Z | L | L1 | L2 | L3 | L4 |
|------------|------|------|------|------|------|----|
| DN15x½"x75 | 25.0 | 42.5 | 75.0 | 11.0 | 21.5 | 55 |



Crane Copper Tube



**Propress™
GAS**

**Propress™
WATER**

Crane Copper Tube

ABN 51 008 408 151
A Division of
Crane Enfield Metals
Pty Limited

PO Box 319,
Penrith, NSW 2751
Phone: 02 4720 5350
Fax: 02 4720 5390
sales@cranecopper.com.au
www.cranecopper.com.au

For Viega enquires please call:
1800 043 117

Dimensions in mm

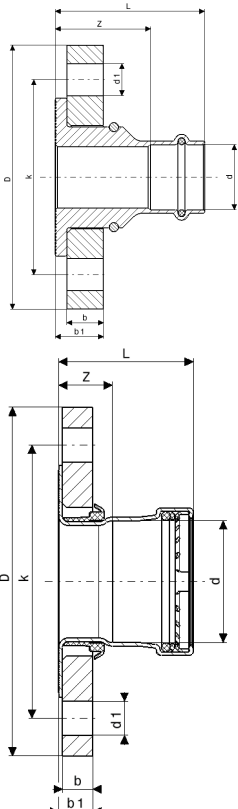
| Flange (AS2129 Table E) | | | | | | | | | |
|--|------|------|-------|-------|------|------|------|----|---|
|  | d | Z | L | D | k | b | b1 | d1 | n |
| DN25 | 38.0 | 61.0 | 115.1 | 83.0 | 12.0 | 17.0 | 14.0 | 4 | |
| DN32 | 41.0 | 66.0 | 120.0 | 87.0 | 12.0 | 17.0 | 14.0 | 4 | |
| DN40 | 48.0 | 79.0 | 135.0 | 98.0 | 12.0 | 17.0 | 14.0 | 4 | |
| DN50 | 47.0 | 86.0 | 150.0 | 114.0 | 12.0 | 17.0 | 18.0 | 4 | |
| DN65 | 28.5 | 71.5 | 165.0 | 127.0 | 16.0 | 18.0 | 18.0 | 4 | |
| DN80 | 28.1 | 78.1 | 184.6 | 146.0 | 16.0 | 18.0 | 18.0 | 4 | |
| DN100 | 31.6 | 91.6 | 215.0 | 178.0 | 18.0 | 20.5 | 18.0 | 8 | |

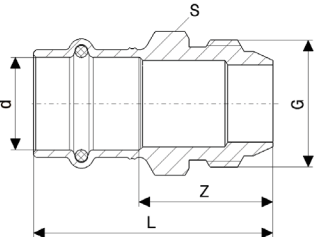
| Flared Male Adaptor | | | | |
|---|-------|------|----|---|
|  | d x G | Z | L | S |
| DN15x1/2" | 27.5 | 45.0 | 22 | |
| DN20x3/4" | 28.0 | 50.0 | 27 | |

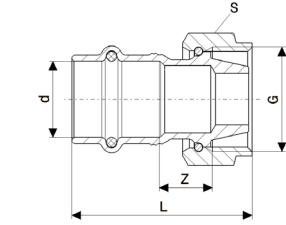
| Union (No.62) | | | | |
|---|-------|------|----|---|
|  | d x G | Z | L | S |
| DN15x1/2" | 11.3 | 37.0 | 24 | |
| DN20x1/2" | 16.3 | 46.5 | 24 | |
| DN20x3/4" | 13.4 | 45.4 | 30 | |
| DN20x1" | 7.9 | 40.5 | 36 | |

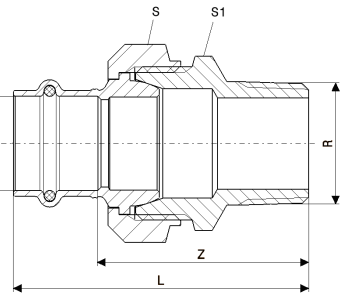
| Union (No.69) | | | | | |
|---|-------|-------|----|----|----|
|  | d x R | Z | L | S | S1 |
| DN25x1 1/4" | 58.1 | 81.1 | 50 | 44 | |
| DN35x1 1/4" | 59.9 | 84.9 | 52 | 50 | |
| DN40x1 1/2" | 61.1 | 92.1 | 60 | 55 | |
| DN50x2" | 73.7 | 112.7 | 78 | 72 | |