

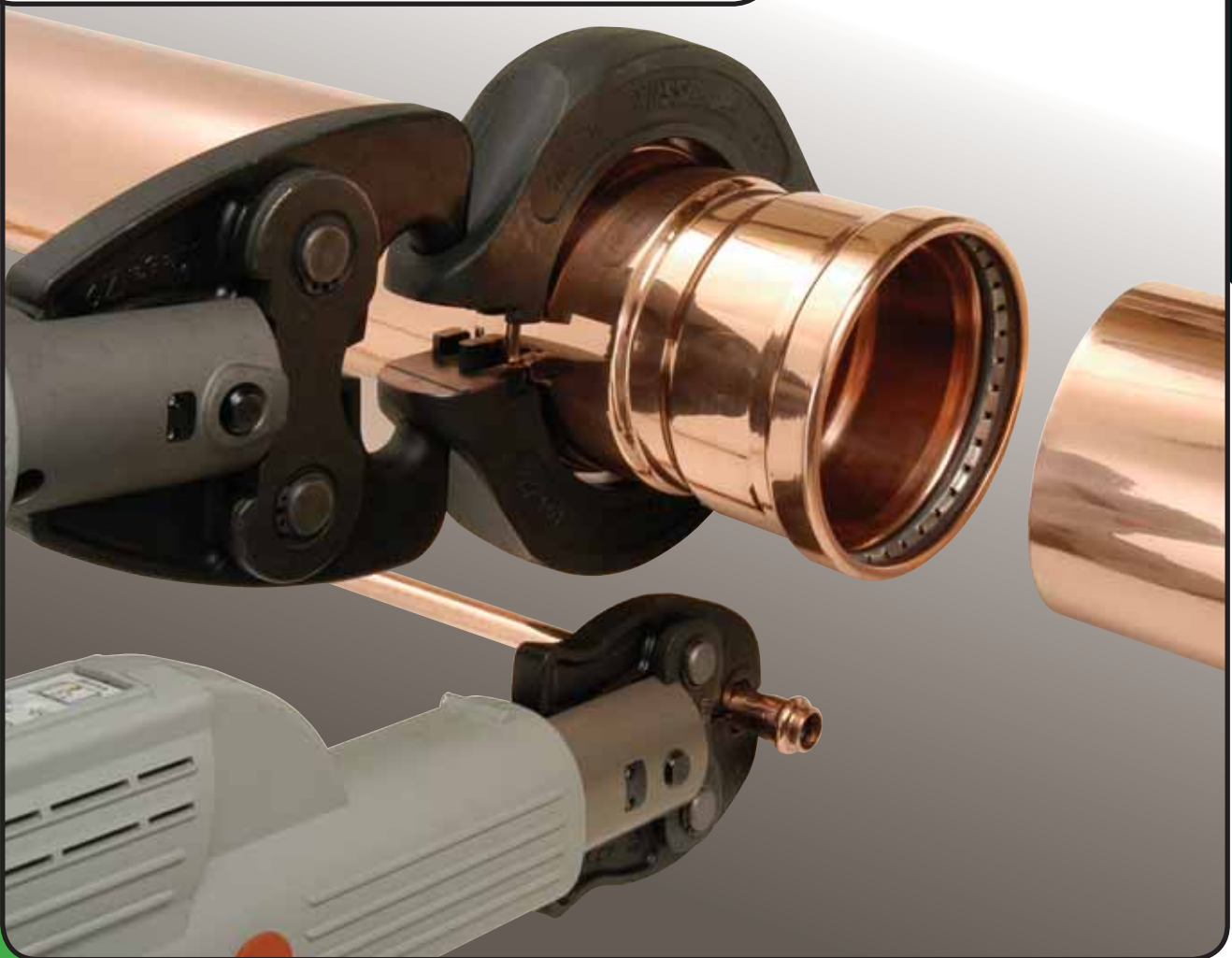

Propress[™]
WATER

Installation & Training Guide



viega

Index

Section	Page
1.0 Introduction	2
2.0 Product Description	3
3.0 The Pressing Process	10
4.0 Installation Requirements	11
5.0 Installation Procedure	15

1.0 Introduction

1.1 The Viega Propress™ System

Copper tubing has been the preferred product for water distribution systems for many decades because of its ease of use, unsurpassed performance characteristics and proven longevity.

With the introduction of the Viega Propress™ press-fit connection system, there is now a far more efficient and cost effective method for joining copper tube for water line applications.

Viega, the company that developed the Propress™ system, has more than 20 years worldwide experience in the use of press connect fittings in copper piping systems. The Viega Propress™ system and fittings have been approved and used extensively in Europe and USA for many years for water systems.

Viega Propress™ fittings suitable for water installations are similar to the Propress™G (gas) fittings but with two main differences.

Propress™ fittings are colour coded with green markings to indicate that they are suitable for water applications only. The sealing element for the Propress™ (water) fittings is BLACK and is made from EPDM rubber (Ethylene Propylene Diene Monomer).

Propress™ fittings also incorporate the Viega patented SC (Smart Connect) feature. This feature provides an easy method for locating unpressed fittings by providing a positive leakage point during testing from any non pressed fitting. When the fitting is pressed, the Smart Connect feature is closed, forming a permanent leak proof joint.

1.2 Approvals and Certification

Viega Propress™ fittings have been tested to AS3688, and have received Watermark approval N°LN21120 for use in hot and cold potable water applications.

Propress™ fittings have also been tested to AS/NZS4020, Testing of products for use in contact with drinking water.

Propress™ fittings are also internationally recognised and approved by agencies such as DVGW, KIWA, DNV, Lloyd's Registry, RINA, Germanischer Lloyd, and Bureau Veritas.

North American approvals include:

- NSF-61 approval for potable water. (National Sanitation Foundation) {test for water quality}
- Full IAPMO UPC listing for potable water. (International Association of Plumbing and Mechanical Officials) (Uniform Plumbing Code)
- CSA listing for potable water (Canadian Standards Association)
- ABS listing for shipbuilding applications. (American Bureau of Shipping)

1.3 Applications

Copper has provided reliable service for many decades and now the Viega Propress™ system effectively enhances the versatility of copper tubing for water delivery applications. Viega Propress™ fittings are manufactured from first grade copper materials and non-ferrous components with proven design life characteristics. The combination of copper tubing and Viega Propress™ fittings ensures water is delivered with no adverse affects on taste, together with the benefits of excellent resistance to corrosion, inherent strength, natural UV and rodent resistance, and now dramatically improved ease of installation with a simple and effective press fit technology that delivers an innovative solution for today's technological challenges.

Propress™ water fittings incorporate an EPDM sealing element, which is approved throughout Australia for potable water applications and can accommodate temperatures of -20°C to 110°C and a safe working pressure of 1600kPa. Where temperatures and/or pressures outside these specifications are required, please consult Crane Copper Tube.

Applications for Propress™ Water fittings include:

- Hot and cold potable water
- Flat panel solar hot water systems
- Grey water, waste and drainage systems
- Compressed air lines (max. 25mg/m³ oil concentration).

1.4 Propress™ Advantages

The advantages of installing copper water lines using Propress™ fittings include:

- Ultra fast assembly and pressing of joints.
 - Improved on-site safety and ease of use with no brazing, soldering or gluing required, and no need to drag gas bottles and hoses around the site.
 - Single action pressing produces a reliable permanent joint in seconds, and reduces the risk of leaking joints and the need for remedial work.
 - No special certification required for installers – must be licensed plumber.
 - Approved for use throughout Australia, and also complies with international codes.
 - Convenient, easy to use, portable battery powered pressing tool reduces on-site equipment and allows easy access even in tight or hard to reach locations.
 - One pressing tool can be used for both water and gas installations.
 - Cost-effective for all water line systems. Excellent for retrofit and remodelling installations. Can be connected to existing copper lines.
 - Can be used on AS1432 Type A, B and C Crane copper tube from DN15 to DN100.
 - Crane copper tube and a comprehensive range of fittings is readily available throughout Australia.
 - Technical field support provided by Crane Copper Tube representatives.
 - Propress™ fittings do not reduce the bore size, and the fittings provide bend radii that are larger than traditional capillary fittings. Flow calculations can be made as per capillary fittings.
 - Can be used behind or in walls, in direct sunlight and underground.
 - Cylindrical tube guide to protect sealing element during assembly.
 - 'Smart Connect' leak detection feature makes un-pressed fittings easy to find.
- Obvious pressing marks also make it easy to identify un-pressed fittings (DN15 to DN50 sizes).

- When used with Crane copper tube, Viega Propress fittings are guaranteed for 25 years against leaks from faulty materials or manufacture, and have a design life of over 50 years.

2.0 Product Description

2.1 Propress™ Water Fittings

Propress™ Water fittings are manufactured in copper (or bronze for threaded fittings) which offer outstanding ductility, durability and corrosion resistance. In addition to these outstanding material properties, the Propress™ fittings also offer the following features:

- Press-fit geometry designed to ensure reliable connections.
- Factory-fitted high-performance EPDM sealing element.
- Integral stop for defined insertion depth.
- Cylindrical tube guides each side of the sealing element to prevent the tube tilting during assembly and pressing.
- Stainless steel grip ring with teeth for increased joint strength in Propress™ XL fittings (DN65 to DN100).
- SC 'Smart Connect' unpressed fitting detection system.
- Propress™ XL fittings also have a tag which is removed after pressing to indicate a completed joint.

For a detailed listing of available fittings, refer to the product data sheets, supplied separately.

2.2 EPDM Sealing Element

Propress™ fittings are manufactured with a high quality EPDM sealing element installed at the factory. This sealing element is approved for all potable water applications.

The sealing element is pre-lubricated, and should not be removed from the fitting. In the event that lubrication is required, use only clean water.

Definition: EPDM – Ethylene Propylene Diene Monomer.

2.3 Copper Tube

Crane copper tube has been tested and approved for use with the Viega Propress™ system. When installed to specifications on Crane copper tube, Propress™ fittings are guaranteed for 25 years against leaks, faulty materials and manufacture.

Propress™ water installations can be made with corrosion resistant copper tube complying with the requirements of AS1432 Type A, B or C.

The dimensions of copper tube used for water installations are shown in Table 2.3.1, 2.3.2 and 2.3.3.

The water installations standard AS/NZS3500: Plumbing and drainage, permits the use of AS1432 Type A, B and C copper tube in above and below ground applications.

Under normal Australian conditions, Propress™ fittings and copper tubing can also be installed outside without any additional corrosion protection. However, where potential aggressive environments exist, precautions should be taken to protect the entire length of piping.

Propress™ fittings are allowed to be installed underground, but it is always good practice to avoid this whenever possible. Copper tubing is available in long lengths and coils, reducing the number of fittings and joints required.

Copper piping should not be placed in direct contact with metal roofs due to the potential for corrosion of the roof material. In such cases, the copper should be raised off the roof with suitable clips. Also, in the event that piping may be exposed to large fluctuations in temperature, at the design stage, provision must be made to accommodate the anticipated expansion and contraction forces that will be imposed on the system.

Crane Copper Tube Specifications

Table: 2.3.1

Type A - Copper Tube to suit Viega Propress Fittings										
Crane Item Number	Nominal Size	Outside Diameter (mm)	Wall Thickness (mm)	Min. Wall Thickness (mm)	Imperial Equivalent O.D. and swg	Nominal Weight (kg/m)	Form	Temper	Safe Working Pressure (kPa) @ ≤50°C	Safe Working Pressure (kPa) @ >50 & ≤75°C
50103075	DN 15	12.70	1.02	0.88	1/2" x 19	0.335	18m coil	Annealed	6100	5060
50103076	DN 15	12.70	1.02	0.88	1/2" x 19	0.335	6m straight	Bendable	6100	5060
50103139	DN 18	15.88	1.22	1.04	5/8" x 18	0.502	6m straight	Hard drawn	5750	4770
50103177	DN 20	19.05	1.42	1.21	3/4" x 17	0.703	18m coil	Annealed	5560	4610
50103179	DN 20	19.05	1.42	1.21	3/4" x 17	0.703	6m straight	Bendable	5560	4610
50103178	DN 20	19.05	1.42	1.21	3/4" x 17	0.703	6m straight	Hard drawn	5560	4610
50103230	DN 25	25.40	1.63	1.39	1" x 16	1.088	18m coil	Annealed	4750	3940
50103231	DN 25	25.40	1.63	1.39	1" x 16	1.088	6m straight	Hard drawn	4750	3940
50103271	DN 32	31.75	1.63	1.39	1 1/4" x 16	1.379	6m straight	Hard drawn	3750	3110
50103293	DN 40	38.10	1.63	1.39	1 1/2" x 16	1.670	6m straight	Hard drawn	3100	2570
50103321	DN 50	50.80	1.63	1.39	2" x 16	2.251	6m straight	Hard drawn	2310	1910
50103348	DN 65	63.50	1.63	1.39	2 1/2" x 16	2.832	6m straight	Hard drawn	1840	1520
50103360	DN 80	76.20	2.03	1.73	3" x 14	4.229	6m straight	Hard drawn	1900	1580
50103372	DN 100	101.60	2.03	1.83	4" x 14	5.677	6m straight	Hard drawn	1500	1250

Annealed
 Bendable

Table: 2.3.2

Type B - Copper Tube to suit Viega Propress Fittings										
Crane Item Number	Nominal Size	Outside Diameter (mm)	Wall Thickness (mm)	Min. Wall Thickness (mm)	Imperial Equivalent O.D. and swg	Nominal Weight (kg/m)	Form	Temper	Safe Working Pressure (kPa) @≤50°C	Safe Working Pressure (kPa) @>50 & ≤75°C
50103045	DN 15	12.70	0.91	0.77	1/2" x 20	0.301	18m coil	Annealed	5290	4390
50103047	DN 15	12.70	0.91	0.77	1/2" x 20	0.301	6m coil	Annealed	5290	4390
50103061	DN 15	12.70	0.91	0.77	1/2" x 20	0.301	6m straight	Bendable	5290	4390
50103133	DN 18	15.88	1.02	0.88	5/8" x 19	0.426	18m coil	Annealed	4810	3990
50103135	DN 18	15.88	1.02	0.88	5/8" x 19	0.426	6m straight	Bendable	4810	3990
50103164	DN 20	19.05	1.02	0.88	3/4" x 19	0.517	18m coil	Annealed	3970	3290
50103165	DN 20	19.05	1.02	0.88	3/4" x 19	0.517	6m straight	Bendable	3970	3290
50103222	DN 25	25.40	1.22	1.04	1" x 18	0.829	18m coil	Annealed	3500	2900
50103225	DN 25	25.40	1.22	1.04	1" x 18	0.829	6m straight	Hard drawn	3500	2900
50103268	DN 32	31.75	1.22	1.04	1 1/4" x 18	1.046	6m straight	Hard drawn	2780	2300
50103291	DN 40	38.10	1.22	1.04	1 1/2" x 18	1.264	6m straight	Hard drawn	2300	1910
50103319	DN 50	50.80	1.22	1.04	2" x 18	1.699	6m straight	Hard drawn	1710	1420
50103339	DN 65	63.50	1.22	1.04	2 1/2" x 18	2.134	6m straight	Hard drawn	1370	1130
50103358	DN 80	76.20	1.63	1.39	3" x 16	3.414	6m straight	Hard drawn	1520	1260
50103369	DN 100	101.60	1.63	1.47	4" x 16	4.577	6m straight	Hard drawn	1200	1000

Annealed
 Bendable

Table: 2.3.3

Type C - Copper Tube to suit Viega Propress Fittings										
Crane Item Number	Nominal Size	Outside Diameter (mm)	Wall Thickness (mm)	Min. Wall Thickness (mm)	Imperial Equivalent O.D. and swg	Nominal Weight (kg/m)	Form	Temper	Safe Working Pressure (kPa) @≤50°C	Safe Working Pressure (kPa) @>50 & ≤75°C
50103033	DN 15	12.70	0.71	0.60	1/2" x 22	0.239	6m straight	Bendable	4070	3370
50103125	DN 18	15.88	0.91	0.77	5/8" x 20	0.383	18m coil	Annealed	4180	3470
50103127	DN 18	15.88	0.91	0.77	5/8" x 20	0.383	6m straight	Bendable	4180	3470
50103153	DN 20	19.05	0.91	0.77	3/4" x 20	0.464	18m coil	Annealed	3450	2860
50103157	DN 20	19.05	0.91	0.77	3/4" x 20	0.464	6m straight	Bendable	3450	2860
50103219	DN 25	25.40	0.91	0.77	1" x 20	0.626	6m straight	Hard drawn	2560	2130

Annealed
 Bendable

2.4 Pressing Tools

The Viega Picco and Pressgun Picco tools are compact, lightweight yet powerful battery-powered electro-hydraulic tools for press-fit joining of Propress™ gas and water installations using DN15, DN18, DN20 and DN25 fittings. (The jaws are not interchangeable with the PT3/4B models).

The Viega PT3 and Pressgun 4B tools will press DN15 to DN100 Propress™G gas and Propress™ Water fittings. (The jaws are not interchangeable with the Picco series tools).

Automatic forced compression, electronic monitoring of bolt safety and temperature, plus battery charge level and service interval display, all make working with the Viega Propress™ tool easy, quick, and so dependable.

The Viega Propress™ tools also provide easy access to hard to reach joints as the head can be rotated. Picco and PT3 heads can rotate up to 90°, while Pressgun Picco and 4B heads can rotate up to 180°.

The Viega pressing tools are manufactured in Switzerland by Von Arx AG, which also manufactures pressing tools sold under the RIDGID® brand name.



Viega Pressgun Picco



Viega Pressgun 4B

2.5 Safety

The Viega pressing tools are power tools that must be used in accordance with this installation and training guide and all of the recommendations which accompany the tool. Under no circumstances should the pressing tools be used for anything other than their intended use.

2.6 Propress™ Fittings

Propress™ fittings are supplied in a colour coded bag (green) to indicate that they are intended for water installations, and are labeled to indicate the fitting type and size. For a detailed listing of available fittings, refer to the product data sheets, supplied separately.



3.0 The Pressing Process

3.1 The 'Smart Connect' (SC) Feature

Propress™ fittings incorporate the patented Viega SC 'Smart Connect' feature, which is a special indentation across the sealing element. The purpose of this indentation is to allow water past the sealing element of any unpressed connection, thereby providing an obvious and highly visible leakage point during system pressure testing.

The indentation is closed during the pressing process, creating a leak-free, permanent connection. This feature provides quick and easy identification of connections, which have not been pressed prior to putting the system into operation. Unpressed connections are located by pressurizing the tubing system with a maximum pressure of 600kPa.

Final system testing must also be carried out as per AS/NZS3500, which requires testing at 1500kPa for 30 minutes.

Figure: 3.1.1 SC 'Smart Connect' Feature



3.2 Removable Tag

Viega Propress™ XL fittings (DN65, DN80 and DN100) are also fitted with removable tags. These tags are to be removed after a fitting is pressed to indicate that the joint is completed.

Figure: 3.2.1

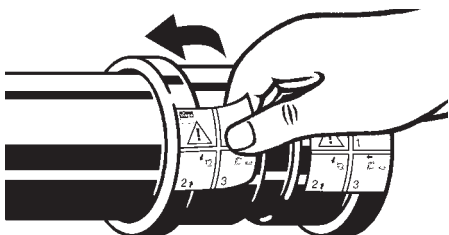

3.3 The Connection Process

The pressing process produces a permanent joint between the fitting and the tubing in a matter of seconds.

For Propress™ fittings (DN15 to DN50) this is achieved by creating hexagonal indentations in front of and behind the sealing element on the press fitting. At the same time, the pressing process reshapes the fitting to encapsulate the sealing element. This positive/non-positive joint ensures a permanent connection. Figure 3.3.1 shows before and after pressing.

Figure: 3.3.1

Before



After

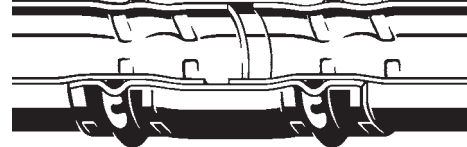

In the case of Propress™ XL fittings (DN65, DN80 and DN100), the pressing process reshapes the fitting in the area of the sealing element and grip ring, ensuring continuous contact between the fitting, grip ring teeth and tubing, and between the fitting, sealing element and tubing.

Figure: 3.3.2

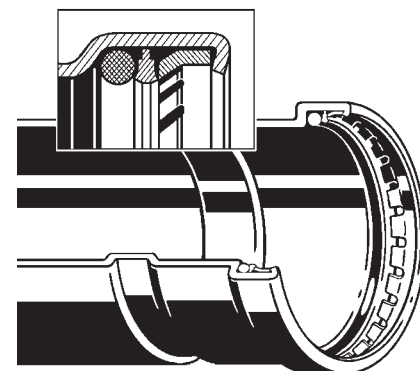

4.0 Installation Requirements

4.1 License and Training

All Propress™ installations must be carried out by a licensed plumber.

4.2 Minimum Clearance Requirements for the Pressing Process.

The minimum clearance required between two tubes and between the tubing and any permanent structure must be taken into consideration. The minimum allowable values are specified in Tables 4.2.1 to 4.2.5.

Table: 4.2.1 Minimum Clearance from a Surface and Adjacent Tubing for Pressing DN15 to DN50.

Tube Size DN (O.D)ø	Picco Series Tools		PT3/4B Tools	
	a	b	a	b
	Minimum Clearance (mm)			
DN15 (½")	25	60	23	64
DN18 (5/8")	25	60	23	64
DN20 (¾")	25	65	26	64
DN25 (1")	25	65	29	76
DN32 (1-¼")	-	-	32	80
DN40 (1-½")	-	-	48	95
DN50 (2")	-	-	54	127

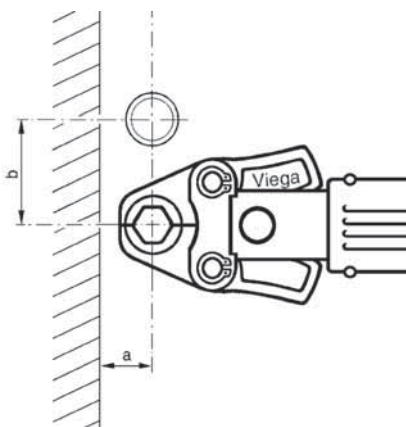

Table: 4.2.2 Minimum Clearance from a Surface and Adjacent Tubing for Pressing XL Fittings.

Tube Size DN (O.D)ø	a	b
	Minimum Clearance (mm)	
DN65 (2-½")	110	185
DN80 (3")	120	200
DN100 (4")	135	215

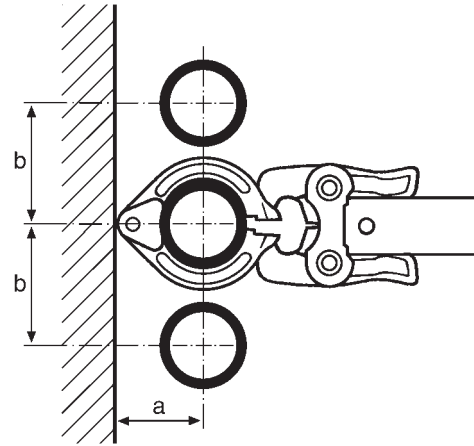

Table: 4.2.3 Minimum Clearance from Internal Corner Surfaces and Adjacent Tubing for Pressing DN15 to DN50.

Tube Size DN (O.D)ø	Picco Series Tools			PT3/4B Tools		
	a	b	c	a	b	c
	Minimum Clearance (mm)					
DN15 (½")	30	40	70	23	35	64
DN18 (5/8")	30	40	70	23	35	64
DN20 (¾")	30	40	75	26	38	64
DN25 (1")	30	40	80	29	45	76
DN32 (1-¼")	-	-	-	32	57	80
DN40 (1-½")	-	-	-	48	64	95
DN50 (2")	-	-	-	54	80	127

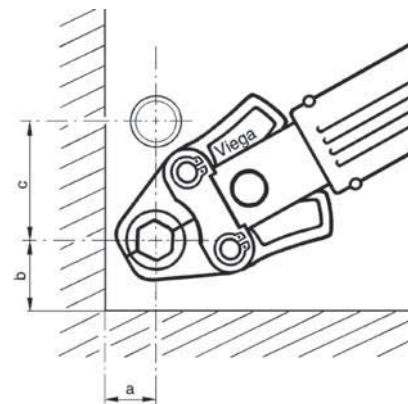

Table: 4.2.4 Minimum Clearance from Internal Corner Surfaces and Adjacent Tubing for Pressing XL Fittings.

Tube Size DN (O.D)ø	a	b	c
	Minimum Clearance (mm)		
DN65 (2-1/2")	110	185	130
DN80 (3")	110	185	130
DN100 (4")	135	215	155

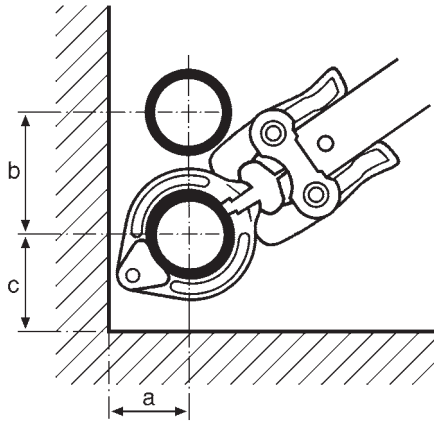
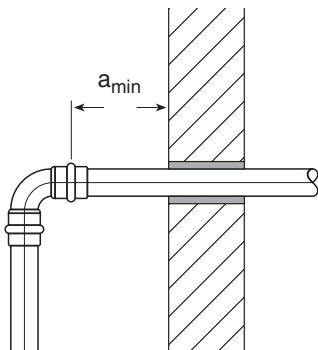

Table 4.2.5 Minimum Clearance Requirements for the Pressing Process in Front and/or Behind Structural Components.

Tube Size DN (O.D)ø	Minimum Clearance 'a _{min} '. (mm)	
	Picco Series Tools	PT3/4B Tools
DN15-DN25 (1/2" - 1")	35	50
DN32-DN100 (1 1/4" - 4")	-	50



4.2.6 Minimum Clearance Between Two Propress™ Connections.

To ensure proper sealing of the press connections the minimum spacing between Propress™ connections must be maintained as per Table 4.2.6.

Note: For installations where the minimum distance is 0 it is particularly important to ensure the correct insertion depth of the tubing into each fitting.

Table 4.2.6

Tube Size DN (O.D)ø	Minimum Clearance a (mm)
DN15 (1/2")	0
DN18 (5/8")	0
DN20 (3/4")	0
DN25 (1")	0
DN32 (1-1/4")	10
DN40 (1-1/2")	15
DN50 (2")	20
DN65 (2-1/2")	15
DN80 (3")	15
DN100 (4")	15

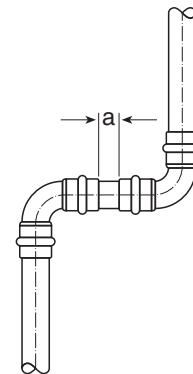

4.2.7 Minimum Clearance Between a Propress™ Fitting and an Existing Brazed Fitting

To ensure proper sealing of both the brazed and Propress™ fitting, the minimum distance must be maintained between the two fittings as per Table 4.2.7.

Table 4.2.7

Tube Size DN (O.D)∅	Minimum Clearance 'a' (mm)
DN15 (½")	6
DN20 (¾")	6
DN25 (1")	10
DN32 (1-¼")	10
DN40 (1-½")	15
DN50 (2")	20
DN65 (2-½")	15
DN80 (3")	15
DN100 (4")	15

Note: It is particularly important that there is no residual solder or other foreign debris on the tubing to be inserted into the Propress™ fitting.

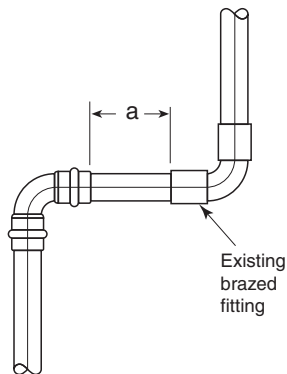

4.2.8 Minimum Clearance Between a New Brazed Fitting and an Existing Propress™ Fitting.

Note: Brazing near existing Propress™ fittings is not recommended and should be avoided.

To ensure proper sealing of both the brazed and press connections a minimum spacing between connections must be maintained. It is important to ensure that the tube inside the Propress™ fitting as well as the fitting itself are not subject to excessive heat when brazing.

It is recommended that brazing does not occur closer than a distance of 25 tube diameters from an existing press fitting. If this is not possible, then the installer must take proper precautions to keep the Propress™ connection cool while brazing (i.e. wrap the connection in a cold wet rag; fabricate brazed connection prior to installation; applying spray type spot freezing product). Table 4.2.8 shows the minimum clearance between a new brazed fitting and an existing Propress™ fitting.

Table: 4.2.8

Tube Size DN (O.D)∅	Minimum Clearance 'a' (mm)
DN15 (½")	318
DN20 (¾")	477
DN25 (1")	635
DN32 (1-¼")	807
DN40 (1-½")	968
DN50 (2")	1291
DN65 (2-½")	1625
DN80 (3")	2000
DN100 (4")	2500

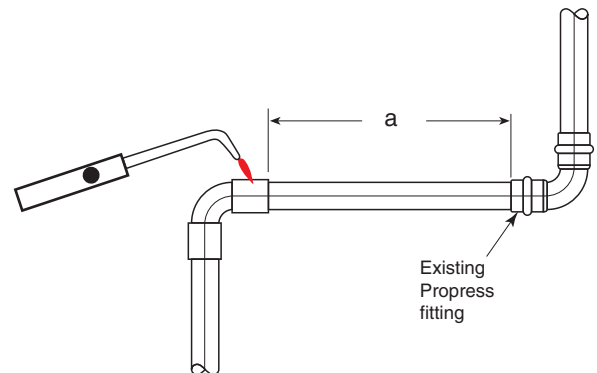

4.3 Tubing Supports

These instructions are in addition to the requirements of AS/NZS3500.

Tube fixing clips perform two functions. One function is to provide support for the tubing system. The second function is to guide the tubing during expansion and contraction changes in the length of the tubing due to changes in temperature. Standard tubing clips can be used to support the tubing. Excessively large spacing between hangers may result in vibration and subsequent noise. Refer to AS/NZS3500 for the standard support spacing.

4.3.1 Spacing of Fixing Clips next to a Change in Direction

Where a large amount of expansion or contraction is expected, fixing clips should not be placed within 100mm of a Propress™ fitting.

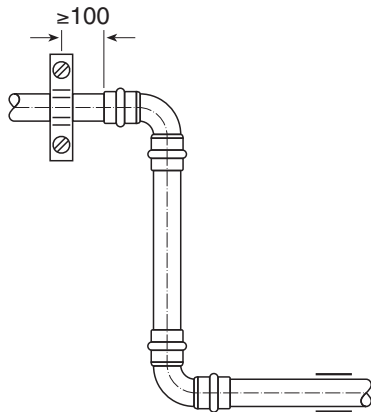

4.3.2 Spacing of Fixing Clips next to a Change in Direction

Due to expansion or contraction a fixing clip placed at right angles could unintentionally fix the pipe. Where a large amount of expansion or contraction is expected, fixing clips should not be placed within 250mm of fittings at a change in direction.

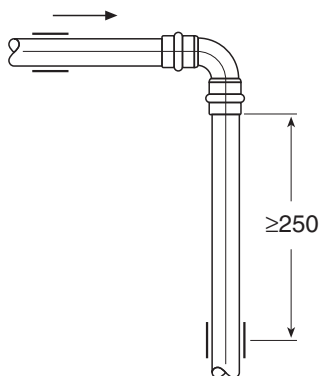

4.4 Cutting Tubing

Copper tubing can be cut to length with a tube cutter or a fine-toothed metal saw. It is not acceptable to cut the tubing with an abrasive cutting wheel or torch. The tubing ends must be deburred both on the inside and outside prior to insertion into the press fitting.

Note: When using Crane copper tube, incise marks present in the joint area will not affect the integrity of the seal. Incise marks in other tube products **MUST NOT** be present in the joint/cut area. Ensure the tube is defect free and that no foreign debris is present at the joint/cut location. Ensure the tube is round and not distorted after the cut has been made.

4.5 Threaded Connections

The Propress™ system can be connected with threaded fittings. When installing threaded connections, the threaded connection is to be completed first and then the press connection, to avoid unnecessary torsional stress.

4.6 Pressure Testing

Propress fittings include the SC 'Smart Connect' system, and unpressed connections are located by pressurizing the tubing system with a maximum pressure of 600kPa.

Final system testing must be carried out as per AS/NZS3500, which requires testing at 1500kPa for 30 minutes.

4.7 Tubing Exposed To Freezing Temperatures

Copper water systems, both soldered and pressed, should not be allowed to freeze. When water freezes it expands and will damage the pipe or the system.

5.0 Installation Procedure

Installation shall be made in accordance with Australian Standard AS/NZS3500, and these installation instructions. All copper tube must comply with Australian Standard AS1432 - Copper tubes for plumbing, gas-fitting and drainage applications and be of Type A, B or C tube. The fitting/tubing system shall not be used as a means of support, and any undue stress or strain on the fittings is to be avoided.

5.1 Installation Procedure for Propress™ Fittings DN15 to DN50.

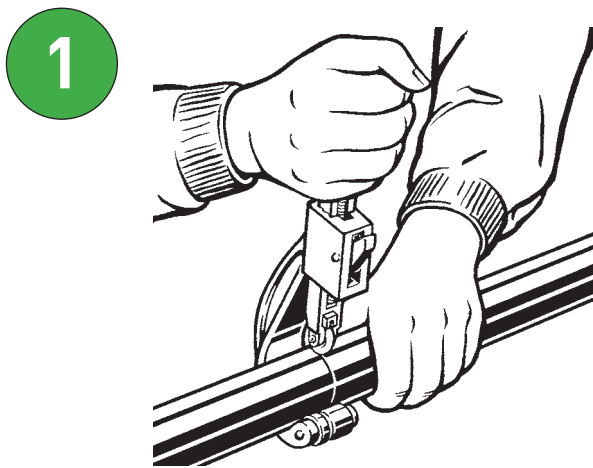

Cut the copper tube at right angles (using a tube cutter or fine-toothed steel saw).

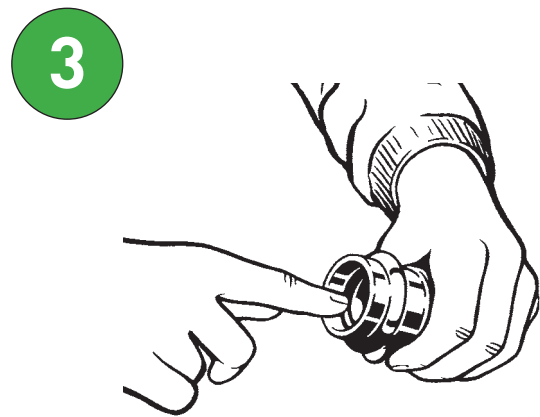

Check the sealing element is correctly seated within the fitting. (The sealing elements are already pre-lubricated so do not apply oil or lubricants, use clean water only if necessary). Use only the original Propress™ Black EPDM seal.

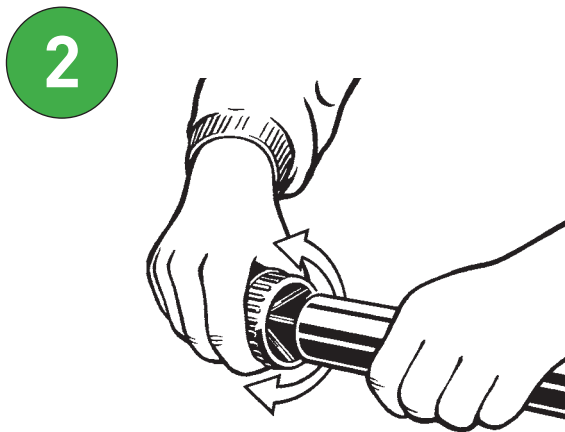

Deburr the end of the copper tube on both the inside and outside.

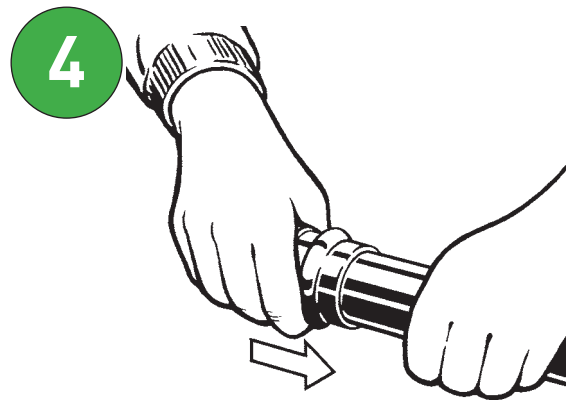

While turning slightly, slide the press fitting onto the tube until it stops.

5

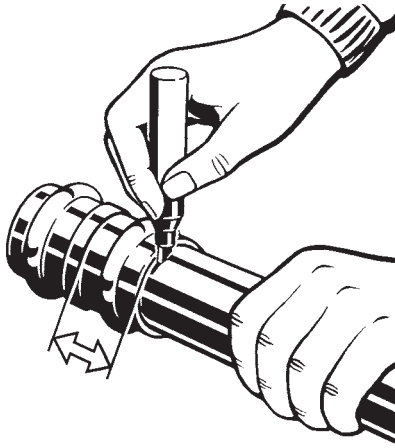

Mark the insertion depth.

7

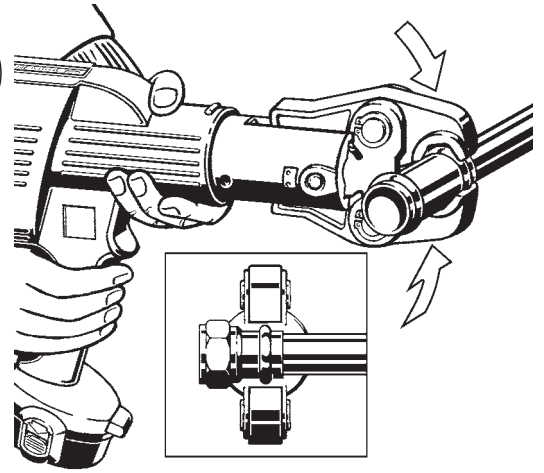

Open the jaws and place them onto the fitting so that the jaws are at right angles to the fitting. Check the insertion depth.

6

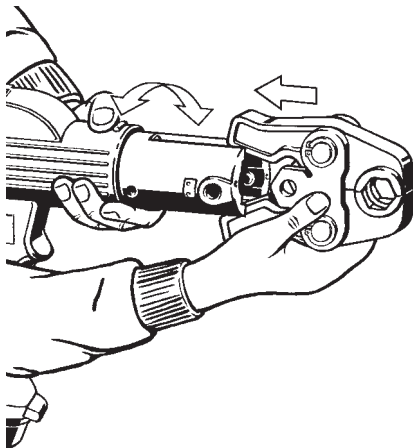

Insert the correct size jaws into the pressing tool and push the holding pin until it locks into place.

8

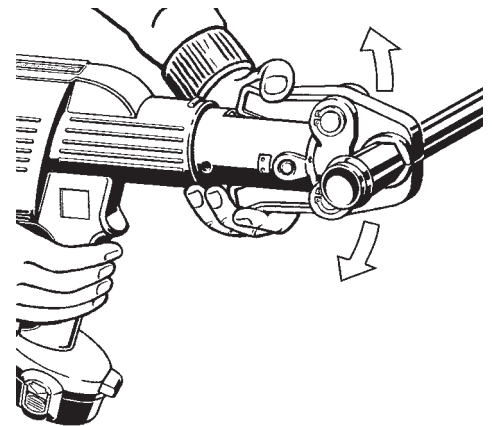

Start the pressing procedure by holding the trigger until the ram has completed the cycle. After completing the pressing procedure, open the jaws and withdraw the pressing tool.

5.2 Installation Procedure for Propress™ XL Fittings

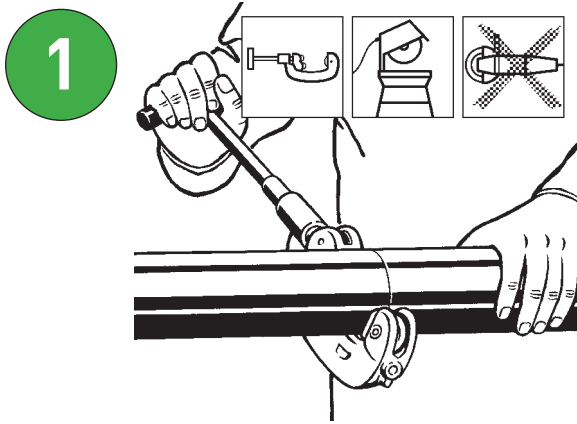

Cut copper tubing at right angles using displacement type cutter or fine-toothed steel saw.

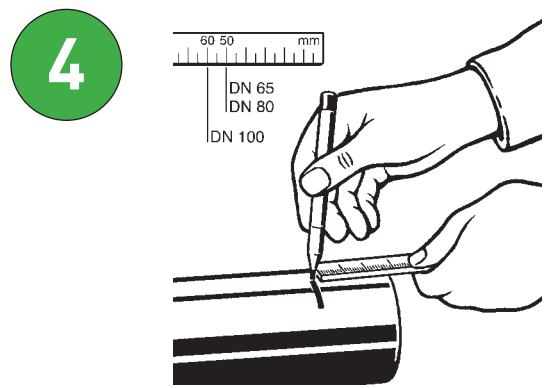

Mark the insertion depth.

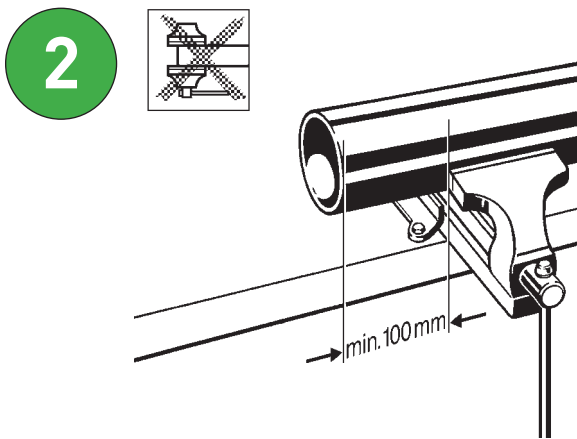

Keep end of tubing a minimum of 100 mm away from the contact area of the vice to prevent possible damage to the tubing in the press area.

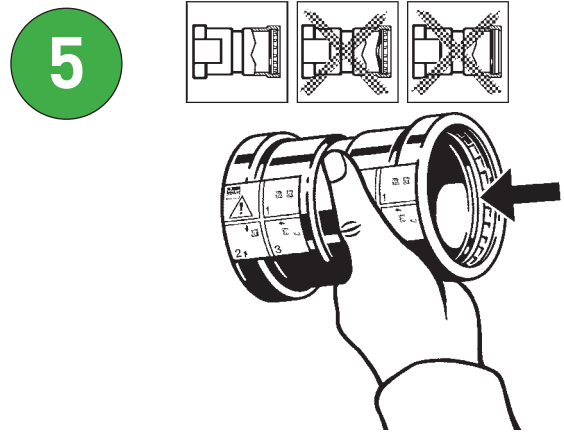

Use only Propress™ fittings with GREEN markings. Check seal and grip ring for correct fit. (The sealing elements are already pre-lubricated so do not apply oil or lubricants, use clean water only if necessary).

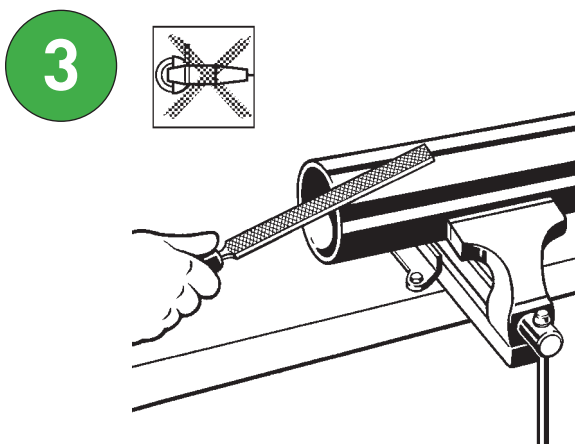

Deburr the inside and outside of tubing to prevent damage to the sealing element.



Illustration demonstrates proper fit of grip ring and sealing element. Use only Propress™ Black EPDM sealing elements.

7

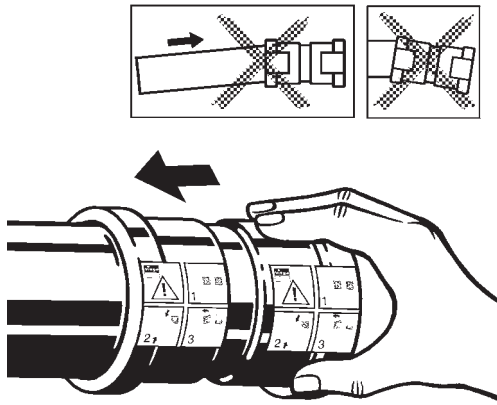

While turning slightly, slide press fitting onto tubing to the marked depth. Do not use oil or lubricants.

10

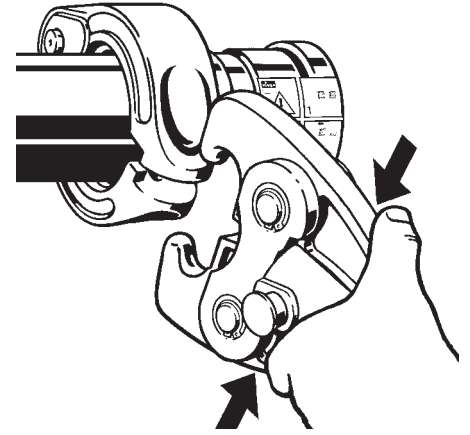

With V2 ACTUATOR fitted into the tool, open the V2 ACTUATOR as shown.

8

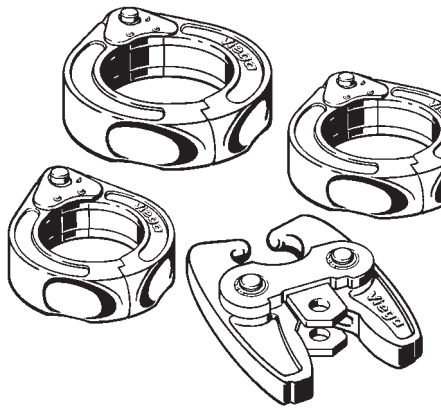

Propress™ XL fitting connections must be performed with Propress™ XL Rings and V2 ACTUATOR. See Viega Operator's Manual for correct tool instructions.

11

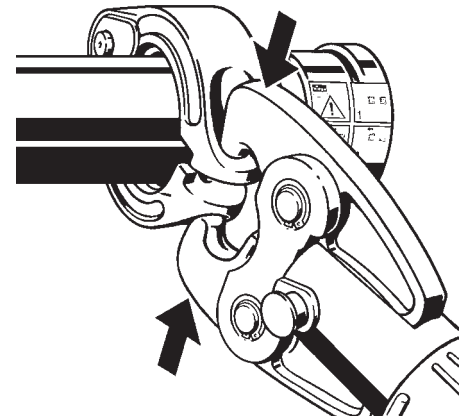

Place V2 ACTUATOR onto XL Ring and start the pressing process. Hold the trigger until the Actuator has engaged the XL Ring. Keep hands and foreign objects away from XL Ring and V2 ACTUATOR during pressing operation to prevent injury or incomplete pressing.

9

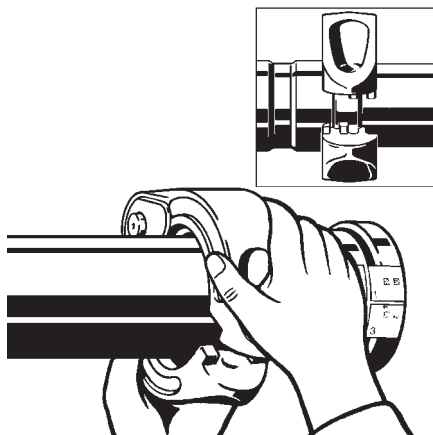

Open XL Ring and place at right angles on the fitting. XL Ring must be engaged on the fitting bead. Check insertion depth.

12

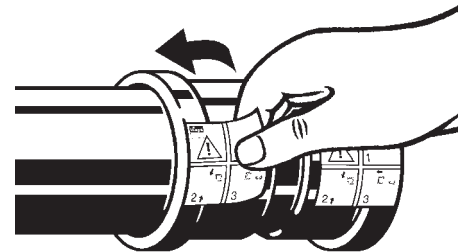

On completion of pressing, release V2 ACTUATOR from XL Ring and then remove the XL Ring from the fitting. Remove sticker from fitting to indicate joint pressing has been completed.



PropressTM WATER



- Ultra fast installation.
- Permanent, strong, leak-free joints.
- No brazing, soldering or gluing required.
- Improves safety and efficiency.
- No need to drag gas bottles and hoses around the site.
- Has Watermark approval for water installations Australia wide.
- Can be used on AS1432 Type A, B and C copper tube.
- Joints can be pressed with pressure in the line.
- Proven track record with over 1 billion fittings in use worldwide.
- German precision engineered and manufactured fittings.
- Guaranteed for 25 years, with a design life of over 50 years.
- Superior pressure and temperature ratings.
- Can be used behind or in walls, in direct sunlight and underground.
- Able to connect to existing copper lines.
- Cylindrical tube guide to protect sealing element during assembly.
- 'Smart Connect' leak detection feature to quickly identify un-pressed fittings. Obvious pressing marks in DN15 to DN50 fittings also assist in identifying un-pressed fittings.
- Fittings supplied in one-piece, ready for installation.
- Full flow joints (fittings maintain bore).
- Comprehensive range of fittings for both water and gas installations.
- One pressing tool can be used for both water and gas.
- Ease of use, yet tool is not cost effective for non professionals.

Information contained in this brochure is provided as a guide only. Crane Copper Tube does not warrant that the information is accurate or without errors or omissions. Crane Copper Tube reserves the right to correct any errors or misprints. All information and product details contained within this document are provided as a guide only. Product use shall be conducted by a fully licensed plumber.

Crane Copper Tube

ABN 51 008 408 151

A Division of Crane Enfield Metals Pty Limited

PO Box 319, Penrith NSW 2751

Phone: 02 4720 5350

Fax: 02 4720 5390

sales@cranecopper.com.au

www.cranecopper.com.au

wCRN9708.BMS1210



Crane Copper Tube